

# Installation, Maintenance, and Repair Manual

## Series 2000SS, 3000SS

### Double Check Valve Assemblies Double Check Detector Assemblies

Sizes: 2½" – 12"

#### ⚠ WARNING



Read this Manual **BEFORE** using this equipment.  
Failure to read and follow all safety and use information can result in death, serious personal injury, property damage, or damage to the equipment.



Keep this Manual for future reference.

#### ⚠ WARNING

You are required to consult the local building and plumbing codes prior to installation. If the information in this manual is not consistent with local building or plumbing codes, the local codes should be followed. Inquire with governing authorities for additional local requirements.

#### ⚠ WARNING

**Need for Periodic Inspection/Maintenance:** This product must be tested periodically in compliance with local codes, but at least once per year or more as service conditions warrant. If installed on a fire suppression system, all mechanical checks, such as alarms and backflow preventers, should be flow tested and inspected in accordance with NFPA 13 and/or NFPA 25. All products must be retested once maintenance has been performed. Corrosive water conditions, and/or unauthorized adjustments or repair could render the product ineffective for the service intended. Regular checking and cleaning of the product's internal components helps assure maximum life and proper product function.

Product information is subject to change without notice and supersedes all previous publications.

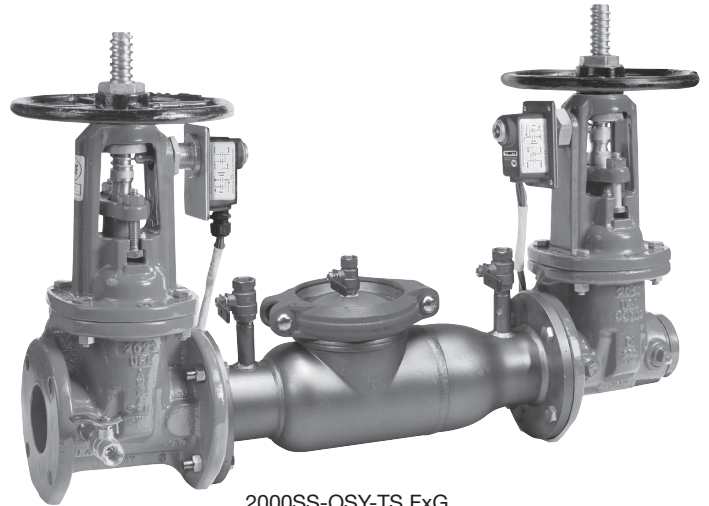

2000SS-OSY-TS FxG  
Integrated supervisory tamper switches on gate valves add protection against fire

#### NOTICE

For Australia and New Zealand, line strainers should be installed between the upstream shutoff valve and the inlet of the backflow preventer.

#### NOTICE

The flange gasket bolts for the gate valves should be retightened during installation as the bolts may have loosened due to storage and shipping.

### Testing

For field testing procedure, refer to Ames installation sheets IS-A-ATG-1 found at [watts.com](http://watts.com).

For other repair kits and service parts, refer to the Backflow Prevention Products Repair Kits & Service Parts price list PL-A-RP-BPD found at [watts.com](http://watts.com).

For technical assistance, contact your local Ames representative.

# Installation Guidelines

- Before installing an assembly, flush the line thoroughly to remove all debris, chips, and other foreign objects. Failure to do so may make the assembly inoperable.
- Series 2000SS and 3000SS backflow preventers are approved by ASSE (American Society of Sanitation Engineers) to be installed in horizontal or vertical positions as long as the flow indicator arrow in the assembly is pointed in the direction of water flow. Local water authorities must approve all installation configurations.
- Allow sufficient clearance around the installed assembly to conduct testing, servicing, and inspection. Allow a minimum of 12" from the flood level to the bottom of the assembly.
- If the double check valve or double check detector assembly is installed in a vault or pit, be sure proper drainage is available. If sufficient drainage is not available a cross-connection may occur.
- If installing on a protection system, be sure to purge air from the fire system. Fill the system slowly with all inspectors test valves open.
- The control valves on the OSY-TS model have integrated supervisory tamper switches that require connection to a fire alarm control panel.

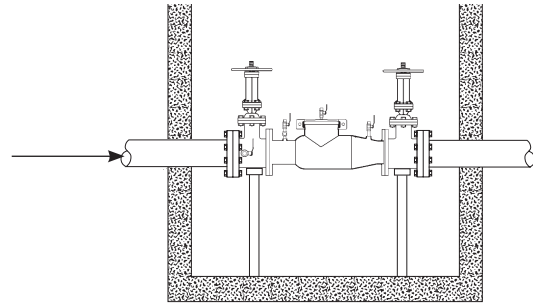

Indoor Installation

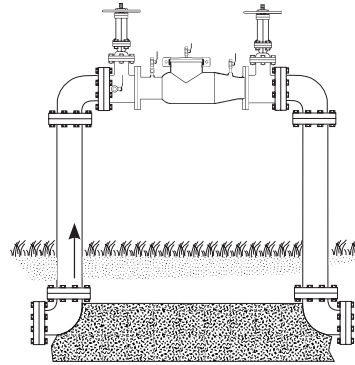

Outdoor Installation

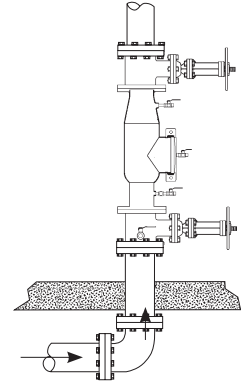

Vertical Installation ASSE

## Wiring the Tamper Switch

The supervisory tamper switch consists of two SPDT switches, and is designed to send a signal when the valve is closed and when the switch is removed from the valve. In the neutral position, the switch indicates the valve is fully open. Closing the valve causes the switch rod to come out of the valve stem groove, activating the switch. Removing the device also activates the switch.

Use the schematic diagram and the wiring notes for proper wiring of the tamper switch to the fire alarm control panel. (For more information refer to Tamper Switch Wiring Instructions at watts.com.)

### CAUTION

Before wiring supervisory switches in fire protection systems, refer to the following standards:

- NFPA 13: Standard for the Installation of Sprinkler Systems
- NFPA 25: Inspection, Testing, Maintenance of Water-based Fire Protection Systems
- NFPA 70: National Electrical Code
- NFPA 72: National Fire Alarm Code
- CSA C22.1 NO.1 Canadian Electrical Code, Part 1, Safety Standard for Electrical Installations Section 32
- CAN/ULC-S524, Standard for Installation of Fire Alarm Systems

### WARNING

Metallic conduit required by NEC for proper grounding conduit joint must be sealed with a conductive sealant.

Install switch in accordance with National Electrical Code and/or local ordinances.

Wiring methods shall be in accordance with CSA C22.1, Canadian Electrical Code, Part 1, Safety Standard for Electrical Installations, Section 32 and CAN/ULC-S524, Standard for Installation of Fire Alarm Systems Assure All Devices Are Properly Grounded.

### Wiring Notes

- Connection to power limited circuitry is required.
- The auxiliary switch is for supplemental use only and shall not be used for fire alarm signaling applications.
- Switch functions are checked at the factory. Checking the switch after field installation is strongly advised. Check continuity with the valve fully open. Switch functions activate within two (2) turns from open.

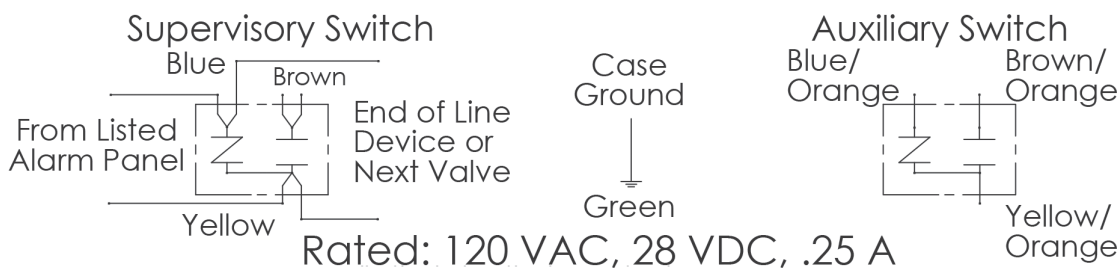

# Maintenance Instructions

**⚠ WARNING** Depressurize valve before servicing.

## Removing Cam-Checks

1. Shut down the water system and lock out the system, if possible. Slowly open all ball valves to relieve air and water pressure. Loosen bolts on the groove coupler and remove the groove coupler and cover plate from the body.
2. For check No. 1, using a 9/16" socket wrench or nut driver, remove the four nuts from the No. 1 check studs. (See Figures 1 and 2.) Using two hands, placing them at 12 o'clock and 6 o'clock, wiggle the cam-check assembly free. Remove the assembly through the access port with the back of the clapper first, spring end down. Pull the assembly out of the main body.
3. For check No. 2, after loosening bolts with a 9/16" socket, remove the bolts completely. (See Figure 3.) Using the centerline access bar, spin the cam-check assembly from the 9 o'clock position to the 12 o'clock position. Then (without letting go of the access bar) push the assembly slightly downstream so that the clapper is parallel with the valve body. Now bring the assembly through the check retaining wall. Leave the assembly clapper parallel with the valve body. Pull the assembly through the access port.
4. Place a 3/8" nut driver or a piece of small diameter pipe on the cam arm torsion spring and move it away from and around the torsion spring retaining bracket so as to relieve the torsion spring tension. (See Figure 4.) This allows the cam arm to move freely, enabling inspection of the clapper face and cam seat. Thoroughly clean the seat area and clapper sealing surfaces, cam arms, and O-rings for damage, nicks, and debris. If any parts are damaged, install a new check assembly O-ring, or washer, shutoff disc.
5. Reassembly reverse of disassembly, carefully tightening the torsion spring, installing the checks, and tightening the studs.
6. Before reinstalling the check assembly, thoroughly clean the O-ring groove and apply an FDA-approved lubricant to the O-ring.

**Figure 1**

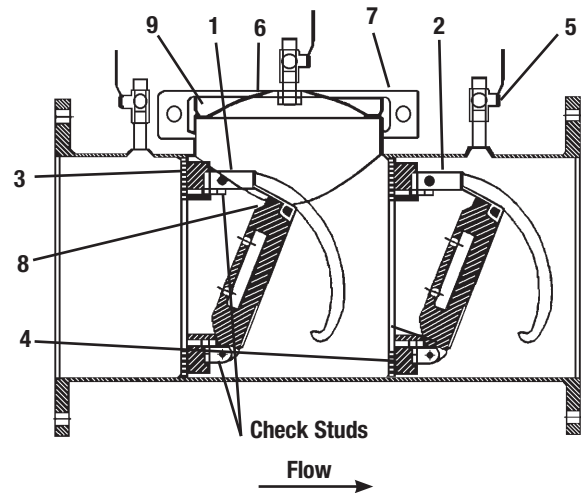

Item	Description
1	No. 1 Cam-Check
2	No. 2 Cam-Check
3	No. 1 Cam-Check O-ring
4	No. 2 Cam-Check O-ring
5	Ball Valve
6	Cover Plate
7	Groove Coupler
8	Washer, shutoff disc
9	Groove Coupler Gasket

**Figure 2**

No. 1 Cam-Check

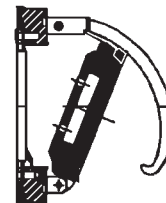

**Figure 3**

No. 2 Cam-Check DC

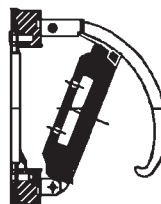

**Figure 4**

Cam arm torsion spring

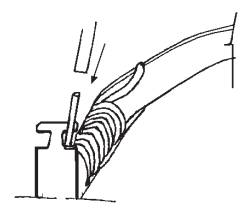

For repair kits and parts, refer to the Backflow Prevention Products Repair Kits & Service Parts price list PL-A-RP-BPD found at [watts.com](http://watts.com).

# Testing Double Check Valve Assembly

## Test Check Valve No. 1

1. Ensure shutoff No. 1 is open and shutoff No. 2 is closed.
2. Connect the high side hose to test cock No. 3, and the low side to test cock No. 2, and open both test cock No. 2 and test cock No. 3.
3. Open valve C, then open A to bleed air from the high side. Close valve A, then open B to bleed low side. Close valve B.
4. Connect the vent hose loosely to test cock No. 1. Open valve A to vent air from the vent hose. Tighten the vent hose at test cock No. 1, and open test cock No. 1.
5. Close shutoff No. 1. Slowly loosen the hose at test cock No. 2 until the differential gauge rises to 2psi then retighten the hose. If the differential reading does not decrease, record the check valves as "tight."

## Test Check Valve No. 2

1. Move the high side hose to test cock No. 4, the low side to test cock No. 3, and open both test cock No. 3 and test cock No. 4. Remove the vent hose from test cock No. 1, and open shutoff No. 1.
2. Open valve C, then open valve A to bleed air from the high side. Close valve A, then open valve B to bleed the low side. Close valve B.
3. Connect the vent hose loosely to test cock No. 1. Open valve A to vent air from the vent hose. Tighten the vent hose at test cock No. 1, and open test cock No. 1.
4. Close shutoff No. 1, then slowly loosen the hose at test cock No. 3 until the differential gauge rises to 2psi and retighten the hose. If the differential reading does not decrease, record the check as tight. Remove all the hoses and restore the valve to original working condition.

### NOTICE

The assembly will fail both the first and second check valve tests above, if shutoff No. 2 leaks excessively. To test for a leaky No. 2 shutoff, use the following procedure.

## Test for Leaky No. 2 Shutoff

1. Connect the high side to test cock No. 1, and the low side to test cock No. 4. Open test cock No. 1 and test cock No. 4. Close shutoffs No. 1 and No. 2.
2. Close valve C. Open valve A, next open valve B 1/2 turn, then loosen the hose at test cock No. 4 to remove air. Retighten the hose.
3. If the differential gauge rises above 0 (zero), there is excessive leakage at shutoff No. 2. The shutoff must be replaced to test the assembly.

## Ball Type Test Valves

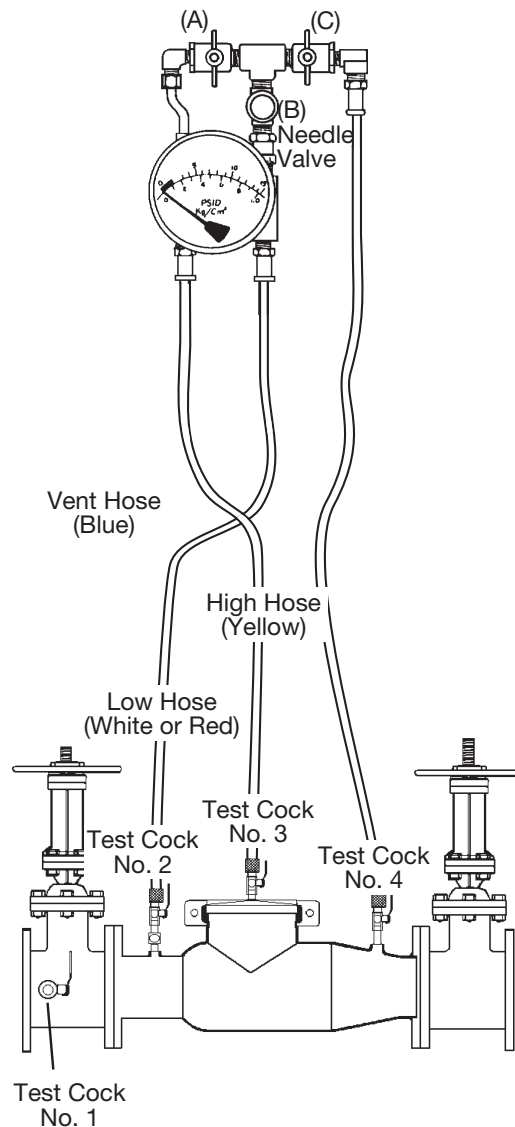

**Limited Warranty:** Ames Fire & Waterworks (the "Company") warrants each product to be free from defects in material and workmanship under normal usage for a period of one year from the date of original shipment. In the event of such defects within the warranty period, the Company will, at its option, replace or recondition the product without charge.

**THE WARRANTY SET FORTH HEREIN IS GIVEN EXPRESSLY AND IS THE ONLY WARRANTY GIVEN BY THE COMPANY WITH RESPECT TO THE PRODUCT. THE COMPANY MAKES NO OTHER WARRANTIES, EXPRESS OR IMPLIED. THE COMPANY HEREBY SPECIFICALLY DISCLAIMS ALL OTHER WARRANTIES, EXPRESS OR IMPLIED, INCLUDING BUT NOT LIMITED TO THE IMPLIED WARRANTIES OF MERCHANTABILITY AND FITNESS FOR A PARTICULAR PURPOSE.**

The remedy described in the first paragraph of this warranty shall constitute the sole and exclusive remedy for breach of warranty, and the Company shall not be responsible for any incidental, special or consequential damages, including without limitation, lost profits or the cost of repairing or replacing other property which is damaged if this product does not work properly, other costs resulting from labor charges, delays, vandalism, negligence, fouling caused by foreign material, damage from adverse water conditions, chemical, or any other circumstances over which the Company has no control. This warranty shall be invalidated by any abuse, misuse, misapplication, improper installation or improper maintenance or alteration of the product.

Some States do not allow limitations on how long an implied warranty lasts, and some States do not allow the exclusion or limitation of incidental or consequential damages. Therefore the above limitations may not apply to you. This Limited Warranty gives you specific legal rights, and you may have other rights that vary from State to State. You should consult applicable state laws to determine your rights. **SO FAR AS IS CONSISTENT WITH APPLICABLE STATE LAW, ANY IMPLIED WARRANTIES THAT MAY NOT BE DISCLAIMED, INCLUDING THE IMPLIED WARRANTIES OF MERCHANTABILITY AND FITNESS FOR A PARTICULAR PURPOSE, ARE LIMITED IN DURATION TO ONE YEAR FROM THE DATE OF ORIGINAL SHIPMENT.**



A WATTS Brand

USA: Backflow T: (978) 689-6066 • F: (978) 975-8350 • AmesFireWater.com

USA: Control Valves T: (713) 943-0688 • F: (713) 944-9445 • AmesFireWater.com

Canada: T: (888) 208-8927 • F: (905) 481-2316 • AmesFireWater.ca

Latin America: T: (52) 55-4122-0138 • AmesFireWater.com