



OWNER'S MANUAL

CLX- XT TRO & Chlorine Monitor

Catalog No. 28030

HF scientific
16260 Airport Park Drive
Suite 140
Ft. Myers, FL 33913
Phone: 239-337-2116
Toll Free: 888-203-7248
Fax: 239-454-0694
Email: hf.info@wattswater.com
Website: www.hfscientific.com

Manual Cat #28652
REV 5 (5/2020)

DECLARATION OF CONFORMITY

Product Safety – Tested and passed:



Part 1: General Requirements UL61010-1 Issued May 11 2012 Ed 3 and CAN/CSA C22.2
#61010-1 issued May 11 2012

Emissions & Immunity – Tested and passed:
EN61326-1: 2013

Enclosure Integrity- Tested and Passed:
IP66 Tested by Intertek

Tested to: IMO MEPC. 174(58) Part 3
Reference Imanna Report # 18953-1

Manufacturer's Name: HF scientific inc.

Manufacturer's Address: 16260 Airport Park Drive, Suite 140, Fort Myers, FL 33913

Importer's Name:

Importer's Address:

Catalog Number : 28030

Type of Equipment: Chlorine Process Monitor

Model No: CLX-XT

I, the undersigned, hereby declare that the equipment specified above conforms to the above Directives and Standards.

A handwritten signature in black ink, appearing to read 'Diana Lefavi', is written over a light gray rectangular background.

Place: Fort Myers, Florida USA

Date: 5/4/2020

(Signature)
Diana Lefavi
Director of Water Quality

Manual Cat #28652
REV 5 (5/2020)

Table of Contents

Section	Page
Specifications	1
1.0 Overview	2
1.1 Unpacking and Inspection of the Instrument and Accessories	2
1.2 The Display	3
1.3 The Touch Pad	3
1.4 Orientation	4
2.0 Safety	4
2.1 Symbols Used In CLX-XT	5
3.0 Theory of Operation	6
3.1 The Measurement.....	6
3.2 The Cooling Chamber.....	7
3.3 The Reagents	7
4.0 Installation and Commissioning	8
4.1 Mounting & Site Selection.....	8
4.2 Plumbing	9
4.3 Electrical Connections	9
4.3.1 Instrument Power	10
4.3.2 Cooling Chamber Power	11
4.3.3 RS-485	11
4.3.4 Relays.....	11
4.3.5 Remote Standby Connections	12
4.3.6 4-20 mA	12
4.3.7 RS-485/4-20 mA Cable Ferrite.....	12
4.4 Installing Reagents	13
5.0 Operation	14
5.1 Routine Measurement (No Control Options)	14
5.2 Routine Measurement (Modbus Control)	14
5.3 Routine Measurement (Remote Standby Control).....	15
5.4 Operating Screens	16
5.5 Security Access Feature	16
5.6 The White LED.....	16
6.0 Instrument Calibration	17
6.1 Slope (gain) Calibration Procedure.....	17
6.2 Zero (offset) Calibration Procedure	18
6.3 Restore Factory Settings	18

Table of Contents (continued)

Section	Page
7.0 Instrument Configuration (CONFIG mode)	19
7.1 Setting the 4-20 mA	19
7.2 Configuring the Error Level.....	19
7.3 Configuring the RS-485 Port	20
7.4 Configuring the Alarms	20
7.4.1 Alarm 1	20
7.4.2 Alarm 2	21
7.5 Enabling the Security Access.....	21
7.6 Extended Settings.....	21
7.7 Units of Measurement.....	22
7.8 Averaging and Filtering	22
7.9 LCD Backlight Brightness.....	22
7.10 RS- 485 Parameters.....	23
7.11 Cycle Time	23
7.12 Water Conservation	23
7.13 4 mA Adjustment.....	24
7.14 20 mA Adjustment.....	24
8.0 Additional Features and Options	25
8.1 RS-485 Output	25
8.1.1 Simple Communication	25
8.1.2 Modbus Communication.....	25
8.2 Remote Panel Meter.....	25
8.3 Desiccant Cartridge.....	25
8.4 Standby Reagent Purge	26
8.5 Reset Reading to Zero.....	26
8.6 AutoPurge	26
9.0 Troubleshooting	27
9.1 CLX-XT Fault Detection	27
9.2 Setting Flow Rate.....	28
9.3 Clearing Faults	28
9.4 Reagent Clogs	29
9.5 Diagnostic Chart	29
9.6 Technical and Customer Assistance	29
10.0 Routine Maintenance	30
10.1 Maintenance Schedule	30
10.2 Replacing or Installing the Reagents	32
10.3 Check Valve Flushing Kit	34
10.4 Instrument Storage	34
10.5 Cleaning the CLX-XT	34
11.0 Accessories and Replacement Parts List	35
12.0 Limited Warranty	36

Specifications

Measurement Range	0.00 – 10.00 mg/L (PPM) or Optional 0.00 – 15.00 Mg/L
Accuracy	<p>Standard 0-10 mg/L range: $\pm 5\%$ of reading or ± 0.03 mg/L (PPM) whichever is greater for range of 0-6.0 mg/L(PPM) & $\pm 10\%$ of reading from 6.01-10.00 mg/L (PPM)</p> <p>Optional 0-15 mg/L range: $\pm 10\%$ of reading or ± 0.03 mg/L (PPM) whichever is greater for the entire range</p>
Resolution	0.01 mg/L (PPM)
Cycle Time	Adjustable; 60 seconds to 10 minutes (600 seconds) Note: the system defaults to 60 seconds (most software versions)
Display	Multi-Line Liquid Crystal Backlit Display
Alarms	Two Programmable, 120-240VAC 2A Form C Relay
Analog Output	Powered 4-20 mA, 600 Ω drive, isolated
Communications Port	Bi-directional RS-485 with Modbus
Water Pressure	Integral pressure regulator 0.34 bar (5.0 PSI) to 10.3 bar (150 PSI.)
Flow Rate to Waste	200 – 400 ml/min.
Operating Temperature	0°C – 55°C (32°F – 131°F)
Wetted Materials	PVC, Borosilicate Glass, Reslyn (FFKM), Viton [®] (FKM), Polypropylene, 316 Stainless Steel, Acetal, Noryl [®] , Silicone, PPS
Sample Temperature Range	0°C – 55°C (32°F – 131°F)
Power Supply	100 – 240 VAC, 47 – 63 Hz, 250VA 100 -240 VAC $\pm 10\%$ for serial numbers 201705625 or greater
Insulation Rating	Double Insulated, Pollution Degree 2, Overvoltage Category II
Environmental Conditions	Not recommended for outdoor use. Altitude up to 2000 meters Up to 95 % RH (non-condensing)
Enclosure Rating	Enclosure certified to IP 66, Fan rated IP 55
Regulatory Compliance And Certifications	Tested to IMO MEPC. 174(58) Part 3 Reference Imanna Report # 18953-1 CE Approved, Listed to UL 61010-1 Ed 3: 2012 Certified to CAN/CSA C22.2 No. 61010-1: 2012 EMC to EN61326-1: 2013
Shipping Weight	11.8 kg (26lbs.) Reagents are Shipped Separately
Shipping Dimensions	63cm X 64cm X 32cm (24.5” X 25 X 12.5”)

1.0 Overview

The CLX-XT TRO & Chlorine Monitor allows for the reading of oxidant levels of process water on-line. The CLX-XT has been designed to meet the design criteria specified by Standard Methods for the Examination of Water and Wastewater (22nd Edition) Method 4500-Cl G. DPD Colorimetric Method. The CLX-XT uses a 515nm LED as the measurement light source.

This instrument has been designed and tested to operate in ambient temperatures of up to 55 °C (131°F). A specially designed thermoelectric cooling chamber has been added to keep the indicator reagent below 25°C (77°F) regardless of the ambient temperature within the operating range of 0 °C - 55 °C. The use of this cooling chamber allows for extended reagent life, up to 3 months.

Every effort has been made to ensure the accuracy of this manual. Due to the continuous development and improvement of all instrumentation, there may be slight differences between this manual and the instrument received. Therefore, no legal claims can be made against any discrepancies herein.

1.1 Unpacking and Inspection of the Instrument and Accessories

The table below indicates the items in the shipment.

Item	Quantity
CLX -XT Monitor	1
Instruction Manual	1
Tubing/Cuvette Kit: 8 black pump tubes, 2 different Cap Assemblies, 1 replacement cuvette	1
Check Valve Flushing Kit	1

Remove the instrument from the packing carton. Carefully inspect all items to ensure that no visible damage has occurred during shipment. If the items received do not match the order, please immediately contact the local distributor or the HF scientific Customer Service Department.

1.2 The Display

Figure 1 illustrates all the items that can appear on the display. The upper row of the display (1) is used for reporting the chlorine levels and to provide user guidance in the customer setting routine. The lower row of the display (2) is used to communicate error messages (message queue) and provide user guidance. The display has two icons (3) that are used to indicate the use of access code and offset mode. In addition, mode arrows (4) are used to indicate the current instrument operating mode; AUTO (normal operation), CAL (calibration) and CONFIG (configuration).

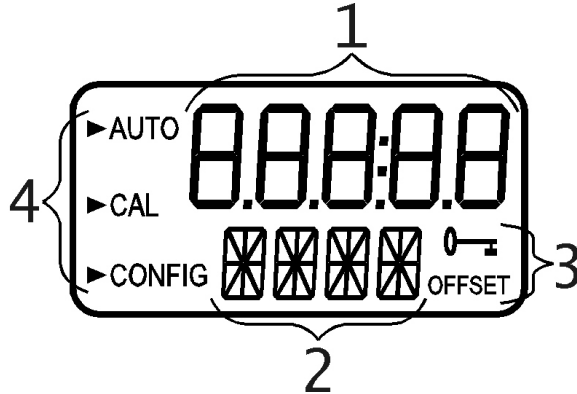

Figure 1: Display used in the instrument.

1.3 The Touch Pad

Figure 2 illustrates the touch pad. The touch pad has six buttons: **PRIME**, **SERVICE**, **MODE/EXIT**, \leftarrow , \blacktriangle and \blacktriangledown

The **MODE/EXIT** button is used to cycle between the three operational modes of the instrument: **CAL**, **CONFIG**, and **AUTO** (Measurement) mode. The \leftarrow button enters the option or mode that is highlighted or chosen. The \blacktriangle and \blacktriangledown buttons are used to change settings.

The **PRIME** and **SERVICE** buttons are dedicated controls. The **PRIME** will start 75 reagent pump pulses to prime the tubing after a change or addition of reagent bottles. The **SERVICE** button will drain the instrument and hold all operations until either the **SERVICE** button is pushed again or the power is reset. This button should be used while changing the tubing, the measurement cuvette or reagent bottles.

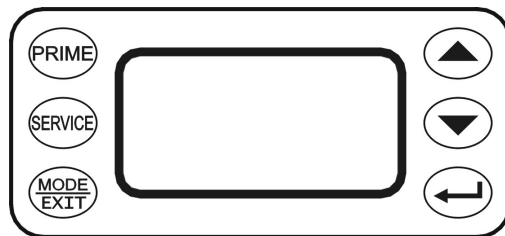
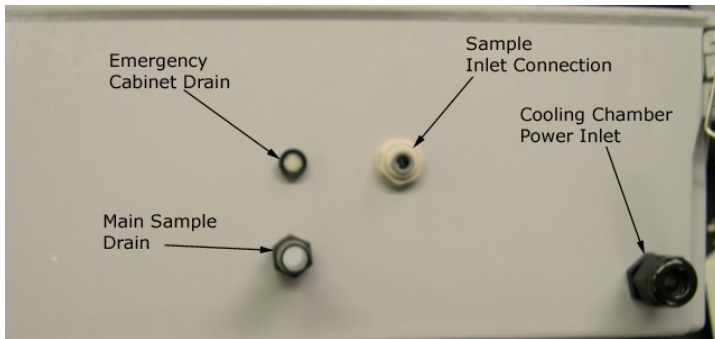

Figure 2: The CLX-XT touch pad.

1.4 Orientation



Front View



Standard Connections

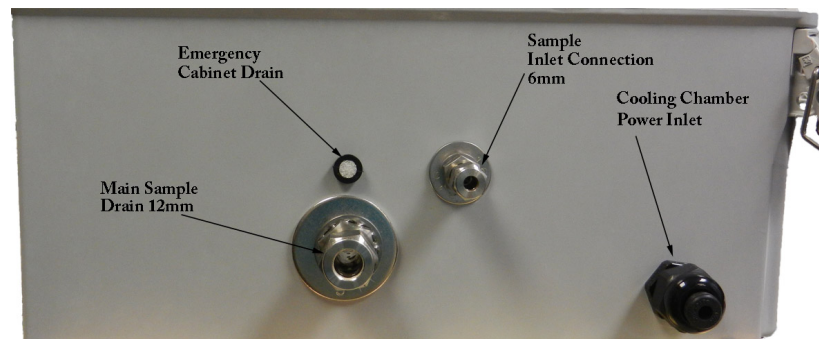

Optional Connections

Bottom View

2.0 Safety

This manual contains basic instructions that must be followed during the commissioning, operation, care and maintenance of the instrument. The safety protection provided by this equipment may be impaired if it is commissioned and/or used in a manner not described in this manual. Consequently, all responsible personnel must read this manual prior to working with this instrument.

In certain instances “Notes”, or helpful hints, have been highlighted to give further clarification to the instructions. Refer to the *Table of Contents* to easily find specific topics and to learn about unfamiliar terms.

2.1 Symbols Used In This Manual



CAUTION

This symbol identifies hazards which, if not avoided, could result in minor or moderate injury.

NOTICE

This symbol identifies practices, actions, or failure to act which could result in property damage or damage to the equipment.



This pictorial alerts you to the need to read the manual.



This pictorial alerts you to electricity, electrocution, and shock hazards.

3.0 Theory of Operation

3.1 The Measurement

The CLX-XT has two solenoid valves, one for sample water (FLOW) and one for draining of the cuvette (PURGE). A third solenoid, along with four check valves forms a reagent pump. Sample water flow is controlled by the FLOW solenoid valve. The PURGE solenoid valve is used to empty the cuvette in the measurement chamber.

The measurement chamber consists of a sample inlet, a purge drain, and an overflow. The reagent is added from the check valves integrated into the lower portion. A green LED provides the 515 nm source lamp, a red LED is used for sample level and flow measurement. A single detector is located 180 ° from the green LED. A replaceable glass cuvette separates the LEDs from the detector and maintains the measurement path length. Sample water flows in the inlet at the bottom, through the measurement cuvette and out through an overflow drain. This flow is used to both fill the cuvette and flush the system.

The reagents are dispensed from two replaceable bottles. One bottle has a buffer to control the pH; the second has an indicator that contains the DPD, which produces color when chlorine is present in the sample. The degree of color is dependant on the amount of chlorine in the sample water.

The measurement chamber is open to view operations. A white LED backlights the chamber for a clearer view. The white LED will flash to attract attention in the case of a warning or failure. Most warnings and failures are also displayed on the screen. To prevent interference, the white LED is turned off during measurements.

During normal operation the CLX-XT will run through a timed cycle. A simplified cycle will consist of the following sequences:

- Flushing – continuous sample flow
- Purging – PURGE valve opens
- Zeroing – no flow with cuvette full
- Adding Reagents – one pulse of the reagent pump
- Mixing with sample – sample flow pulses in
- Reading resulting sample – no flow with cuvette full
- Purging – PURGE valve opens to remove reacted sample

The cycle above is simplified and does not describe all the actions and testing that occurs. The CPU continuously diagnoses the entire system for correct operation and sample water flow. If an error occurs, a message is posted to the message queue on the LCD screen.

The reagent is added by a single pulse of the reagent solenoid. When the reagents require replacement, the **PRIME** button is pushed to bring new reagents into the system. During **PRIME** the reagent solenoid is pulsed several times to draw fluid from the two reagent bottles and fill the tubes with new reagent. A complete **PRIME** takes less than a minute.

The **SERVICE** button empties the cuvette, stops the flow of sample water, and clears any errors. This provides a convenient way to replace reagents and the measurement cuvette. If more extensive servicing is performed, all power to the CLX-XT should be removed. If the CLX-XT is to be turned off, it is recommended that the instrument be placed in **SERVICE** mode before removing power. This ensures that the cuvette is emptied and the flow is off.

3.2 The Cooling Chamber

The CLX-XT has a unique feature that allows for extended reagent life. Under temperature conditions above 25°C the indicator reagent would quickly oxidize resulting in low readings.

To control this condition the CLX-XT has a built-in cooling chamber for the indicator reagent. The temperature of this chamber is kept below 25°C in ambient temperatures of up to 55°C. This cooling chamber will cycle similar to a normal refrigerator to keep the indicator reagent at the desired temperature. This temperature is factory set and should not be adjusted.

To allow for this feature to operate correctly, this cooling chamber must be constantly powered.

On the right side of the enclosure is a fan. This is required for proper operation of the cooling chamber and must never be blocked.

3.3 The Reagents

The indicator reagent reacts with any oxidant, generally chlorine, to create a pink color which the instrument measures and compares with a sample of water without reagents.

The buffer reagent is required to control the sample pH to bring the sample to neutral.

The reagents are provided already hydrated and require little operator preparation.

The indicator reagents are packaged a plastic box. Each 125 mL indicator will require the addition and mixing of the DPD powder contained in the small brown bottle. This activates the indicator reagent. The indicator reagents should be changed out on a 90 day basis even if they are not fully used.

The 500 ml buffer does not require any preparation and is good for one year.

After one year all the reagents will have been consumed and a replacement reagent set will be required. This can be ordered through agent Catalog No.09991. This set will include a new plastic box with four sets of Indicator reagents plus one 500 mL bottle of Buffer.

4.0 Installation and Commissioning

Prior to use for the first time, one of the reagents (the indicator) will have to be mixed. Refer to section [10.2 Replacing or Installing the Reagents](#).

4.1 Mounting & Site Selection

The instrument is designed for wall mounting. If wall mounting is not practical, the instrument can be mounted on any suitable level surface. Choose a location that is easily accessible for operation and service and ensure that the front display rests at eye level. Consideration must be made the plumbing connections. The overall mounting dimensions of the instrument are shown in Figure 3.

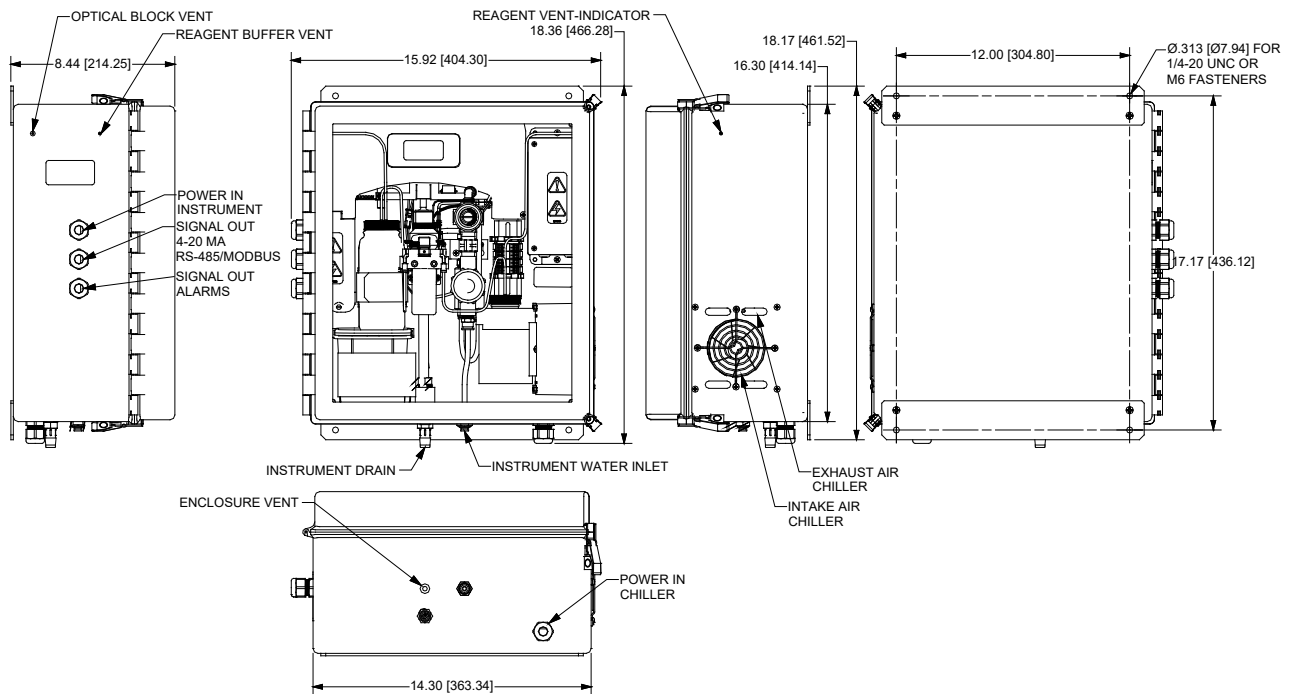

Figure 3: Overall Mounting Dimensions of the Instrument

It is critical that the instrument be mounted as close as possible to the sampling point to ensure a quick response time (within 2-3 meters (6-10 ft) of the sampling point).

Suggested mounting screws are up to M6 (1/4”).

4.2 Plumbing

The instrument is designed to require very little head pressure to operate, but will need around 0.34 bar (5 PSI). The maximum pressure for proper operation should not exceed 10.3 bar (150 PSI). The maximum allowable fluid temperature is 55°C (131°F).

Opaque tubing is recommended be used if the tubing will be exposed to sunlight, to prevent algae growth. Please note that the supplied sample inlet connector is compatible with ¼" O.D. semi-rigid or rigid tubing.

The instrument is equipped with an internal cabinet drain (vent) to prevent damage in the event of a tubing failure.

The main sample drain tubing connects to a hose barb. The rated tubing size is ½" ID tubing. It is recommended that opaque tubing be used to prevent algae growth. Keep this tubing as short as possible. This drain must be kept open to the atmosphere.

NOTICE

The drain must be open to the Atmosphere for proper operation.

NOTICE

The fluid waste from drain connection of this instrument contains reagents diluted with large quantities of sample water. If this is only drained into the ballast water stream it is safe to discharge overboard. In most instances this wastewater should be returned to the ballast tanks

4.3 Electrical Connections

Most of the electrical connections to the instrument are made at the termination area which is located on the left side of the instrument. Remove the high voltage cover by loosening the captive screw. The connections are labeled and are self-descriptive (see photo below). Please follow all local and government recommendations for installation of electrical connections to and between the instrument and other peripheral devices.

Plugs are inserted into the RS-485 and 4-20mA cable bulkheads when shipped, to ensure a watertight seal. These plugs should be removed and discarded when cabling to either of these connections.

The power cable bulkhead will accept cable diameters from 5.8mm (0.23 in.) up to 13.9 mm (0.53 in.). All terminals are designed to accept wires in the range of 14-28 AWG. All wires should be stripped to a length of 6 mm (¼"). A strain relief strap is provided to reduce tension on the power terminals.

It is the user's responsibility to assure that a watertight seal is maintained after the CLX-XT has been wired for operation. If any of the bulkheads are not tightened properly around a cable or plug, the ratings of the instrument will be jeopardized and there is a possibility of creating a shock hazard.



Only qualified electricians should be allowed to perform the installation of the instrument as it involves a line voltage that could endanger life.

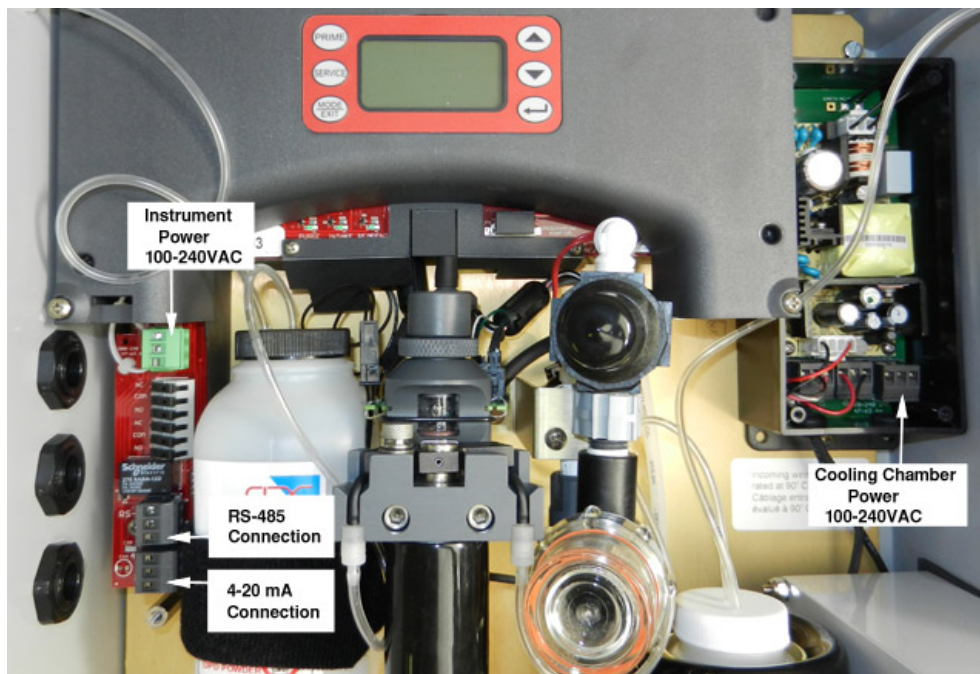

4.3.1 Instrument Power

The instrument is equipped with 100-240 VAC, 47-63 Hz power supplies requiring 150VA; please verify that the line voltage falls within these specifications. A circuit breaker must be placed prior to the power connection in close proximity and within easy reach to allow for service. This circuit breaker must be marked to indicate that it is a disconnecting means for the instrument. While making connections, refer to the photo shown above.

The CLX-XT is intended for cord connection with a three wire non-locking grounded power cord, however rigid or flexible conduit connections can be used. **The CLX-XT is not supplied with a power cord.** If the CLX-XT is to be used in the U.S. or Canada the power cord must be UL Listed & CSA Certified. Please consult all local electrical codes for proper connection. All wiring to the instrument must be rated for 70 °C or higher.

**Power
100-240VAC**



The connection block is marked N for Neutral and L for line the third symbol indicates a secure earth ground. The green removable terminal block is suitable for wire gauges 18 to 12 AWG. In addition a chassis common earth bond point is provided on the chassis below the instrument safety access cover.

An optional connection is shown below. In this case the power to the measurement and cooler are made at this termination block. This termination will be located above the reagent cooling chamber.

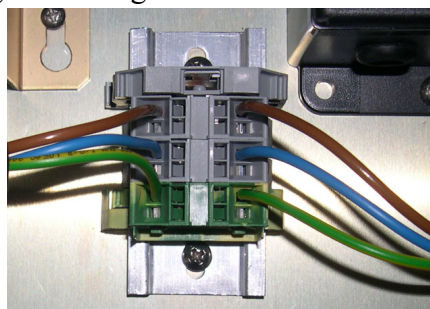

4.3.2 Cooling Chamber Power

Power must be connected to the cooling control box mounted on the top right side of the cabinet. The requirements are 100-240VA, 47-63 Hz and 100VA. A circuit breaker must be placed prior to the power connection in close proximity and within easy reach to allow for service. This circuit breaker must be marked to indicate that it is a disconnecting means for the cooling circuit for the instrument. All wiring to the cooling chamber must be rated for 90 °C or higher.

This supply is separated from the instrument power connection because the cooling chamber must be operated full time to prevent premature degradation of the indicator reagent. Power cable enters from the bottom of the cabinet. The connection block is marked N for Neutral and L for line the third symbol indicates a secure earth ground. The removable terminal block is suitable for wire gauges 18 to 12 AWG. In addition a chassis common earth bond point is provided on the chassis

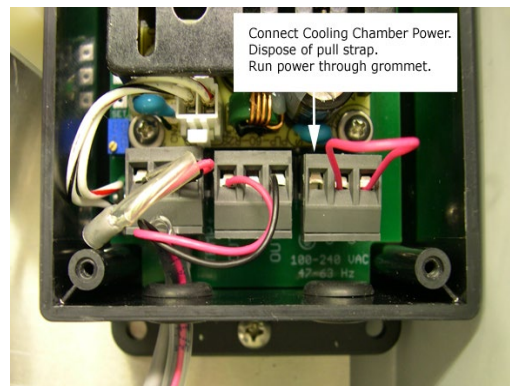

below the instrument safety access cover. **4.3.3**

4.3.3 RS-485

The RS-485 half-duplex (2-wire) digital interface operates with differential levels that are not susceptible to electrical interferences. This is why cable lengths up to 3000 ft can be implemented. The last device on each bus may require terminating with a 120 ohm resistor to eliminate signal reflection on the line. Do not run RS-485 cables in the same conduit as power. Set-up of the RS-485 is covered in [7.3 Configuring the RS-485 Port](#)

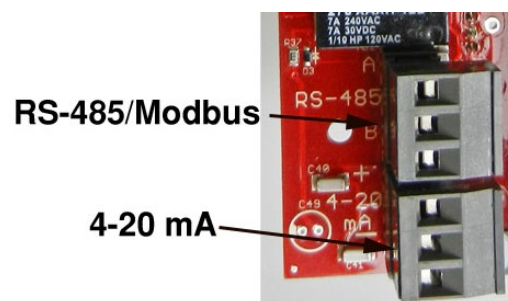

To prevent damage to the instrument, ensure that power is disconnected prior to making connections. For ease of connecting, remove the plug-in terminal block. Connections are labeled beside this termination on the PC board. The recommended cable is 22 AWG shielded twisted pair. The grey terminal block is removable to assist in making connections.

4.3.4 Relays

The Alarm 1 and Alarm 2 relays are mechanical relays rated at 240 VAC 2A. Please note that the relays are labeled NO (Normally Open), NC (Normally Closed) and C (Common). As these alarms are configured fail-safe, the normal condition is with power applied to the CLX-XT and in a non-alarm condition. Operation of these alarms is covered in section [7.4 Configuring the Alarms](#).

The lever operated terminal blocks are rated for wire gauges 28-14.

4.3.5 Remote Standby Connections (Cat #25264)

This option allows the instrument to operate on special user control software and hardware, where an external control initiates each cycle. This control line is called RSI or Remote Standby Input.

The CLX-XT will indicate the current status on another line called RSO or Remote Standby Output. These are a relay contact that is closed when busy (operating) and open when in standby mode.

The connections are labeled RSI and RSO. The RSI has + and – polarity connection associated with it and requires a 24VDC control signal.

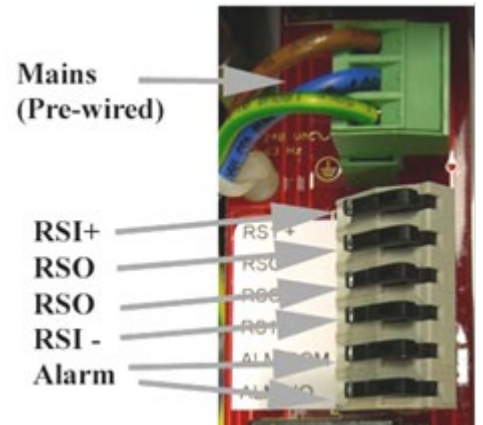

The RSO is simply a relay contact and is not polarized.

The use of this option lowers the relays to one Normally Open connection.

4.3.6 4-20 mA

The 4-20 mA output is driven by a 15 VDC power source and can drive recorder loads up to 600 ohms. Transformer isolation is provided on the CLX-XT. Do not run 4-20 mA cables in the same conduit as power. Operation of this output is covered in section [7.1 Setting the 4-20 mA](#).

To prevent damage to the instrument, and for general safety ensure that power is disconnected to the CLX-XT prior to making any connections. Polarities of the connections are labeled beside this termination on the PC board.

The recommended cable is 22 AWG shielded twisted pair. To prevent ground loops, connect the shield at **either** the CLX-XT or at its destination, but not both. The grey terminal block is removable to assist in making connections.

The 4-20mA is factory calibrated. An adjustment is available on the 4-20mA in sections [7.13](#) and [7.14](#). In addition to making adjustments, these menus output continuous 4 mA or 20 mA and can be used as a signal test. Remember that the configuration mode will timeout after 15 minutes.

4.3.7 RS-485/4-20 mA cable Ferrite

To meet IEC requirements for RF radiated immunity a clamp-on type ferrite is supplied in the accessory kit. It should be placed on the RS-485 or 4-20 mA cable outside, as close as possible to the CLX-XT. If both outputs will be used, an additional ferrite will be needed and can be ordered from HF scientific Catalog number 24560T.



4.4 Installing Reagents

The CLX-XT will require that two reagents be installed prior to operation. These are a buffer and an indicator. A 12 month supply of reagents can be ordered under catalog no. 09991. For reagent preparation refer to section *10.2 Replacing and Installing the Reagents*. The reagent life was made under assumption that the CLX-XT would be used for ballast water monitoring and the system will operate only while the vessel is ballasting and discharging ballast water.

The Buffer is ready to use and is provided in a 500 ml bottle. The indicator requires some preparation and is supplied in four 125 ml bottles. Each indicator reagent will last a maximum of 3 months based on reagent aging when kept in the operating cooling chamber.

5.0 Operation

The CLX-XT TRO values are reported in milligrams per Liter (mg/L), or if preferred the equivalent Parts Per Million (PPM).

Readings above 10.00 mg/L are outside the range of this instrument. Although the CLX-XT may display above 10.0 mg/L, these readings will not be within the stated accuracy. As the reagents degrade due to aging, readings above 10.0 mg/L may decrease in value.



For the optional 0-15 mg/L range the reading mentioned above are extended to 15.00 mg/L (Catalog #28895).

5.1 Routine Measurement (No Control Options)

Using this model instrument the CLX-XT will continuously operate and provide one reading every cycle. It is important to note that the only way to stop the instrument is by manually placing the instrument in SERVICE mode. If the power is interrupted the instrument will automatically start in the AUTO (cycle) mode.

First, ensure that all plumbing and electrical connections are complete before continuing.

The following steps describe how to measure the value of chlorine of a sample using this instrument:

1. Apply power to the instrument and allow the unit to warm up (typically 45 minutes to one hour on initial commissioning).
2. When a continuous process stream is flowing through the instrument, the instrument will display the measured chlorine level of the sample by displaying it on the LCD screen. In addition, the equivalent signal is provided on the analog (4-20 mA) output, or the digital (RS-485) output, depending on the options selected.

5.2 Routine Measurement (Modbus Control Option Cat# 25316)

Most versions of CLX-XT software allow Modbus control. Using this control the system will provide one cycle and provide one updated reading each time it is prompted. It will then go into standby mode and await another prompt.

First, ensure that all plumbing and electrical connections are complete before continuing.

The following steps describe how to measure the value of chlorine of a sample using this instrument:

1. Apply power to the instrument. The instrument will perform a water calibration (WCAL). This automatic calibration is necessary and will only be performed once on power up.
2. When the instrument has completed the WCAL it will enter standby mode and is ready to run a measurement cycle.
3. Subsequent measurement cycles must be initiated from Modbus using the Coil Address 00005. The default is False (0). Setting this address to True (1) initiates the cycle.
4. Each cycle will take about 60 seconds after which the reading screen will be updated. The 4-20 mA and alarms will be representative of this reading.

At any time the standby status can be checked by either Modbus Coil Address 00005 or Input Address 10005. False (0) indicates standby True (1) indicates measurement cycle active. Control is only possible through Modbus Coil Address 00005.

5.3 Routine Measurement (Remote Standby Control Option Cat # 25264)

The CLX-XT can operate using Remote Standby Control. Using this optional hardware control the system will provide one cycle and provide one updated reading each time it is prompted. It will then go into standby mode and await another prompt. The prompt is a 24VDC signal applied to two contacts.

First, ensure that all plumbing and electrical connections are complete before continuing.

The following steps describe how to measure the value of chlorine of a sample using this instrument:

1. Apply power to the instrument. The instrument will perform a water calibration (WCAL). During this time the RSO contact will be closed, indicating the system is busy. This automatic calibration is necessary and will only be performed once on power up.
2. When the system has completed the WCAL, the RSO contacts will open indicating that it is in standby mode and is ready to take a measurement.
3. Application of 24VDC to the RSI connections will initiate a read cycle. The RSO contact will close to indicate the system is busy.
4. At the completion of the cycle, the RSO contacts will open & the measured chlorine level of the sample will be displayed on the LCD screen. In addition, the equivalent signal is provided on the analog (4-20 mA) output, or the digital (RS-485) output, depending on the options selected.
5. The system is now ready to take a new measurement.

Continuous application of 24VDC to the RSI will result in continuously updated readings.

The instrument needs to take one reading first before proper operation. After the first reading the operation will continue as below:

- Whenever the instrument is in standby the reading will be 0.00 this means the associated 4-20mA signal will be representative of this reading. If the alarm is set to LO or HI it will respond to this 0.00 reading.
- Whenever the instrument is taking a reading the 4-20mA output and alarm response will be representative of the reading on the LCD screen.
- New readings will be updated as long as 24VDC is applied to the RSI connections.



5.4 Operating Screens

During normal operation, the instrument will have the arrow beside **AUTO** highlighted with the current scale displayed on the lower row of the display and the measured reading on the upper row of the display (see screen shown).

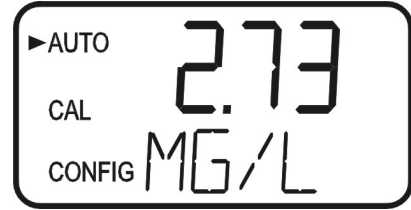

The screen shown to the right indicates that the system has just been started or just entered **AUTO** mode from Service mode and no readings have been taken yet.

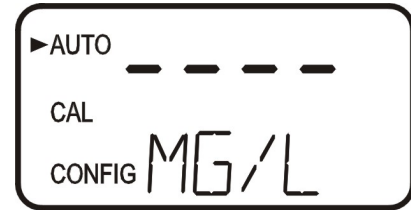

Please note that calibrations will not be allowed until a reading is posted.

5.5 Security Access Feature

The instrument is equipped with a security access code feature that can be activated in the configuration mode. If the security feature is enabled, the screen shown in the illustration below will appear when the **MODE/EXIT** button is pressed.

The security code (333) must be entered to gain access to **CAL** or **CONFIG** menus. Notice that the first number in the code is flashing. The flashing indicates that this is the number to be changed. Use the ▲ or ▼ arrows to select the first of the three numbers in the code and then press the ← button to accept the first number of the code. Now enter the second number in the code. Proceed as with the first number followed by ←. Then repeat the process for the third number in the access code, and finish with the ← button.

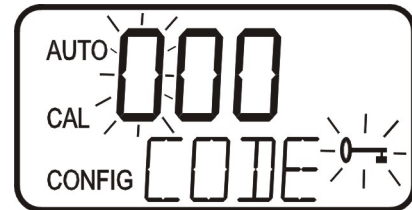

If the valid access code has been selected, the instrument will be directed to the calibration mode. If the wrong access code is selected, the instrument will return to the **AUTO** mode. Refer to section [7.5 Enabling the Security Access](#) for more information.

5.6 The White LED

A white LED is used to illuminate the measurement cuvette for easy viewing of the instrument operations. During the Zeroing portion of the cycle and the Measurement portion of the cycle, when the green LED is active, the white LED is turned off to lower interference. This normal operation for the instrument and does not represent an error or problem.

The white LED is also used to draw attention to a problem as described in section [9.1 CLX-XT Fault Detection](#). In these instances the white LED blinks at a constant rate dependant on the severity of the problem, but is still turned off as described above. Please note that any fault is always posted to message queue on the lower portion of the LCD.

6.0 Instrument Calibration

The instrument was tested prior to leaving the factory. The instrument operates from a pre-determined calibration curve for high accuracy of residual oxidant concentration. It is not necessary to recalibrate to maintain accuracy specifications.

If re-calibration is required by a regulatory authority, this can easily be performed if required. The method is by comparison against another instrument, such as a laboratory or hand held photometer (such as HF scientific's Chlorine Pocket Photometer).

There are two points of calibration. The slope or gain and the zero (offset). To perform the zero calibration, the instrument must be plumbed to a sample of known chlorine free water, such as de-ionized water for a zero adjustment.

6.1 Slope (gain) Calibration Procedure

It is important that the chlorine level be quite stable to use this method. The comparison will be made against a trusted measurement such as a chlorine photometer, spectrophotometer, or an amperometric titration.

1. Obtain a grab sample of the flow prior entering the instrument.
2. Measure the value of the sample with one of the methods shown above.
3. On the CLX-Xt, press the **MODE/EXIT** button once. The screen is shown below.

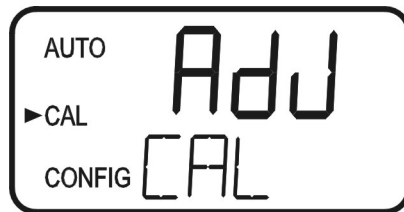

4. Press **↵** to enter the calibration adjustment.



5. The screen will show the current reading on the CLX-Xt. Using the **▲** & **▼** buttons adjust the reading to agree with the laboratory method or portable photometer.
6. Press **↵** to accept the calibration adjustment and return to **AUTO** measurement mode.

NOTICE

There is a limit to the size of the change that can be made to a current reading. The upper limit is the current reading times 1.5. The lower limit is the current reading divided by 1.5.

Ensure a reading is posted to the display before calibrating to avoid a nOnE error.

6.2 Zero (offset) Calibration Procedure

Generally this calibration is only required if readings are expected to be below 1 mg/L or if it is required by a regulatory authority. To perform this calibration, the water supply to the CLX-XT must be changed to chlorine free water such as de-ionized water. This chlorine free water must be run through the instrument for at least 5 minutes prior to using the following procedure.

1. On the CLX-XT, press the **MODE/EXIT** button once. The screen is shown below.

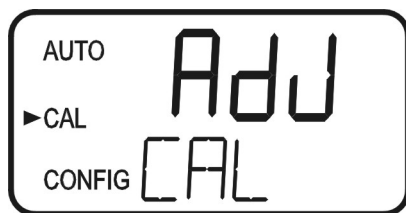

2. Press either the ▲ or ▼ buttons to get the following screen.



3. Press ← to enter the zero calibration screen.

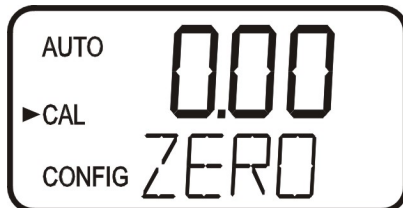

4. The screen will show the current reading on the CLX-XT. Since there is no chlorine, the only reading may be a slight offset due to the absorbance of the reagents. There should be no pink color developed.
5. Press ← to perform a Zero calibration. When the calibration has completed the instrument will return to **AUTO** measurement mode automatically.

NOTICE

There is a limit of ±0.20 mg/L total adjustment available. A ZERO Cal. greater than this will cause a CAL warning and no calibration will have occurred. Enter SERVICE mode to clear this error.

6.3 Restore Factory Settings

If the CLX-XT displays a CAL error or the calibration was incorrectly performed, it may be preferred to restore the factory calibration. All factory defaults settings including the factory calibration can be reset by holding down the ▲ button and then pressing and releasing the ← button then releasing the ▲ button.

7.0 Instrument Configuration (CONFIG mode)

The instrument has been designed to provide the ability to customize the instrument according to needs at any time during normal operation. This mode has been split into sub-menus to facilitate instrument configuration. This section describes how to use each of the sub-menus to configure the instrument. While in the configuration mode, the instrument has a time-out feature that automatically returns the system operation to the **AUTO** mode after a fifteen (15) minute period of no button pushes.

Enter the **CONFIG** mode of the instrument by pressing the **MODE/EXIT** button until the arrow beside **CONFIG** is illuminated, then press the \leftarrow button to scroll through the sub-menus.



To exit the CONFIG mode, press the MODE/EXIT button any changes that were made will be saved.

7.1 Setting the 4-20 mA Output

The first configuration selection is **4-20** for the 4-20 mA output. Select the either **On** or **OFF** using the \blacktriangle and \blacktriangledown buttons. Once the desired output has been set, press the \leftarrow button to accept it. The next prompts will depend on the output selected. Also see sections [7.13](#) & [7.14](#).

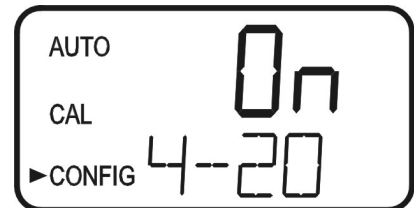

If the 4-20 mA output was turned **On**, prompts to set the 4mA (**4MA**) and 20mA (**20MA**) chlorine limits will be displayed. There will also be a menu to adjust the error level (ERLV). The first prompt will be the chlorine limit assigned to the 4 mA output level:

Select the chlorine level to assign to the **4MA** using the \blacktriangle and \blacktriangledown buttons.

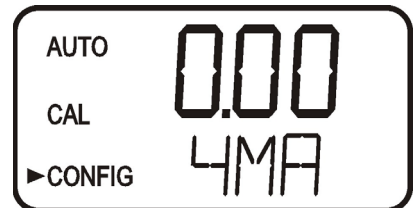

Once the desired level has been set, press the \leftarrow button to accept it.



The 4MA can be set higher than 20MA level to invert the output current if required. This may be required to control a dosing pump.

The next prompt will be the chlorine level assigned to the 20MA. Select the chlorine level using the \blacktriangle and \blacktriangledown buttons. Once the desired level has been set, press the \leftarrow button to accept it.

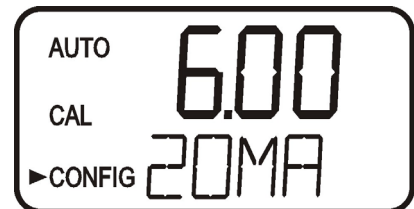

7.2 Configuring the Error Level

In case of an error in the CLX-XT, the 4-20 mA reading can be used to indicate a problem by sending the current to either 4.00 mA, 2.00 mA or 0 mA. The factory default setting is OFF. Select the desired ERLV by using the \blacktriangle and \blacktriangledown buttons then press the \leftarrow button to accept the desired error response.



7.3 Configuring the RS-485 Port

The instrument is equipped with an RS 485 port which operates in Simple bus or Modbus. Prompts will appear for setting the baud rate, the address and the Modbus transmission mode (RTU or ASCII).

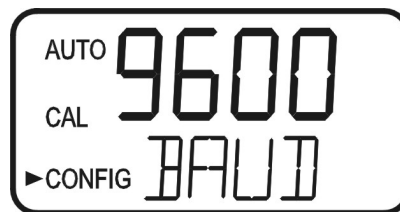

Select the correct baud rate (1200, 2400, 4800, 9600, or 19200) for operation of the I/O port by pressing the ▲ or ▼ buttons to change the displayed baud rate.

Press the ← button to continue on and select the desired instrument address using the ▲ or ▼ buttons. Once the selection is satisfactory, press the ← button.



To use the Modbus mode, select ASCII or RTU. See section 8.1.2.

7.4 Configuring the Alarms

Two relays are provided that are designed to operate as two independent programmable alarms or as a system problem alarm. Please note that changes to alarms will not be recognized until the start of the next cycle. Two settings must be selected to fully program each alarm:

1. The alarm function (HI, LO, OFF or Error)
2. The alarm set point (level at which the alarm activates)

These items are described below:

Alarm Function: The alarms can either be turned OFF or selected to operate in one of three different manners:

1. HI alarm: the relay changes state when the measured chlorine level is higher than the programmed alarm level (set point).
2. LO alarm: the relay changes state when the measured chlorine level is lower than the programmed alarm level (set point).
3. Error alarm: If there is a system fault or problem the alarm will change states.

Alarm Set Point: The level at which an alarm activates is called the alarm set point. On the instrument, the alarm set point is designated as "S/P". The set point is adjustable to any valid chlorine level over the range of the instrument in steps of 0.01 mg/L. This setting is not available if the Error function is chosen.

7.4.1 Alarm 1

Alarm 1 Function: The ALM1 is displayed and the display indicates the current function of alarm 1 (**HI, LO, OFF, or Error**). Use the ▲ or ▼ buttons to cycle through and select the desired function. Press the ← button to accept the selection.

If the alarm was turned **OFF**, a prompt will appear to set up alarm 2 (go to section 7.4.2).

Alarm 1 Set Point: This prompt is used to select the set point for this alarm; this is indicated by “S/P” shown on the lower row of the display. Select the desired alarm level by using the ▲ and ▼ buttons. Once the desired set point has been set, press the ↵ button to accept it.

7.4.2 Alarm 2

Repeat the procedure listed in section 7.4.1 to set up the parameters for alarm 2. If a selection was made to turn the alarm **OFF**, the next selection for the speed of response **RESP** is shown.



The use of the Remote Standby Option 25264 limits the relays to a single Normally open connection. Follow Alarm 1 Instructions.



Due to the cyclic nature of the CLX-XT, relay chatter is not an issue. There is no need for alarm delays or hysteresis.

7.5 Enabling the Security Access

The instrument is equipped with a security access. If this option is turned on, the user is required to input the access code into the instrument to get to any mode other than **AUTO**. The only code is **333**. This code may not be changed. See section 5.2 for more information on this security feature. The security key icon will be visible and flashing on the display whenever the access option is selected using the ▲ or ▼ buttons. (**On** or **OFF**).

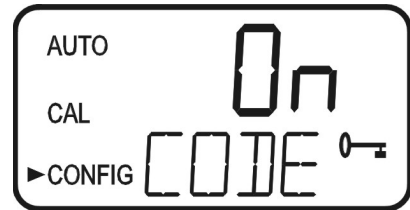

7.6 Extended Settings

The last settings are grouped together to prevent them from being adjusted by accident. To gain access to the extended settings, select **On** using the ▲ or ▼ buttons and press the ↵ button.

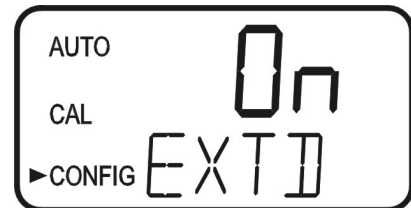

If extended settings are set to **OFF**, pressing the ↵ button will save all settings and the CLX-XT will automatically return to the normal **AUTO** mode of the instrument.

7.7 Units of Measurement

The unit of measure can be set to either mg/L (milligrams per liter) or PPM (parts per million). The factory setting is mg/L. Select the desired UNIT using the ▲ and ▼ buttons and press the ↵ button to accept it.



mg/L screen



PPM screen

7.8 Averaging and Filtering

The CLX-XT can display and output averaged readings to help smooth out the response and eliminate large reading variation in rapidly changing processes. There are 5 settings for the averaging feature:

- 1 = No averaging, each reading is in “real time”.
- 2 = The current reading and previous reading are averaged.
- 3 = The current reading and previous 2 readings are averaged.
- 4 = The current reading and previous 3 readings are averaged.
- 5 = The current reading and previous 4 readings are averaged.

The factory setting is averaging of 2. Select the desired AVG using the ▲ and ▼ buttons and press the ↵ button to accept it.

In addition to averaging, the CLX-XT has a software filter that limits the change between consecutive readings to 20%. For example, the reading following a reading of 1.00 ppm could not be displayed as higher than 1.20 ppm or lower than 0.80 ppm. This filter also helps smooth out large changes and eliminate reading spikes. After 3 consecutive readings, it is assumed that the large change in the readings is "real", and the filter will be disabled. For example, the change between reading 1 & 2, and readings 2 & 3 will be limited to 20%, but the change between readings 3 & 4 will not be limited.



This software filter is completely disabled when the averaging (AVG) is set to 1.

7.9 LCD Backlight Brightness

The LCD backlight brightness may need to be adjusted. This is of particular interest if multiple instruments are located in the same area and it is desired for the entire group to have the same appearance. Ten levels are available. The factory setting brightness is 8.

Change the brightness by pressing the ▲ or ▼ button. When the desired brightness has been selected, press the ↵ button.



7.10 RS-485 Parameters

These menus will only appear if the RS-485 is enabled (see 7.3). The factory setting is 8 Bit, no (nOnE) Parity, 1 Stop Bit.

Make selections using the ▲ and ▼ buttons then press the ↵ button to move to the next menu.



7.11 Cycle Time

The cycle time can be changed using this menu. **Please note that changing this menu will directly affect the volume of reagent that will be consumed.** The default is set to 60 seconds (1 minute).

Make selections using the ▲ and ▼ buttons then press the ↵ button. Allowable setting is from 60 to 600 seconds (10 minutes).

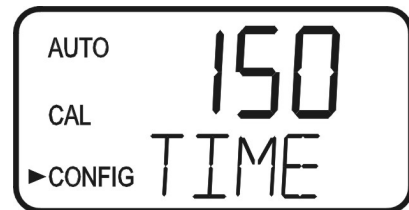

The indicator reagent has a defined life after being mixed regardless of the cycle time setting. If the reagent is kept in the powered cooling chamber the life is 90 days.

7.12 Water Conservation (if available)

To conserve water, the flush time can be adjusted use as little water as possible.



This feature is generally not used in ballast water applications and should be set to OFF.

The instrument requires 110 seconds to complete its normal operations, when the **WCON** is turned **On**, at the factory cycle time the instrument sits idle for about 40 seconds. This results in about a 25% water savings. The actual amount of water conservation is dependent on the incoming water pressure and the cycle time setting.



The use of this option may result in some slight loss of accuracy. The factory setting for this option is **OFF**.

Make selections using the ▲ and ▼ buttons then press the ↵ button to exit to **AUTO** mode and save all configuration settings. If the 4-20 mA in section 7.1 is turned ON, there are two additional menus that will appear before returning to **AUTO** mode.

7.13 4mA Adjustment

If the 4-20 mA setting is turned ON (7.1 *Setting the 4-20 mA Output*), the following two menus will appear. The first menu outputs a constant 4 mA while allowing for a small amount of adjustment. The adjustment can be made using the ▲ and ▼ buttons. This adjustment will allow the operator to make the CLX-XT agree with a PLC or SCADA system. The adjustment limits are ± 200 counts or about ± 0.2 mA.



This setting will be slightly different on each instrument as each CLX-XT will be factory set to 4.00mA. Press the ↵ button when adjustments are complete to save this setting and move on to the 20mA adjustment.

7.14 20mA Adjustment

This menu operates similar to the previous menu. This menu outputs a constant 20 mA while allowing for a small amount of adjustment. The adjustment can be made using the ▲ and ▼ buttons. The adjustment limits are ± 1000 counts or about ± 1 mA.

This setting will be slightly different on each instrument as each CLX-XT will be factory set to 20.00mA.



When complete with the 20mA adjustment, press the ↵ button to exit to **AUTO** mode and save all configuration settings.

8.0 Additional Features and Options

8.1 RS-485 Outputs

The CLX-XT has the capability to operate in two different RS-485 modes. Included are a simple communication mode and Modbus communications. Both modes will automatically configure and do not require any changes or selections

8.1.1 Simple Communication

The CLX-XT can provide basic communications over simple programs such as the Hilgraeve HyperTerminal that is included with most Microsoft Windows packages. The user could also use Visual Basic or other programs. The factory setting communication parameters are 8 bits, no parity and 1 stop bit. These can be changed in the Extended **CONFIG** menus [7.10 RS-485 Parameters](#).

The master computer will send out:

- Byte #1 the attention character “:” in ASCII or 3A Hex
- Byte #2 the address of the CLX-XT being queried
- Byte #3 & 4 CR LF or 0D 0A in hex

The CLX-XT will respond with:

The CLX-XT will respond with:

- The same attention character “:” in ASCII or 3A Hex
- The address of the CLX-XT
- The Reading
- The Unit (mg/L)

A sample communication would look like this:

(Master computer requesting a report from address #1) :1 CRLF
(CLXB set to address #1 Response) :001 0.0249mg/L

8.1.2 Modbus Communication

Modbus protocol communication is included with this instrument. The Modbus address list is available from HF scientific or online at www.hfscientific.com.

8.2 Remote Panel Meter (Catalog # 19609)

The remote panel meter allows for remote indication of the mg/L reading using the 4-20 mA loop of the CLX-XT. No external power is required, as the meter is run off of the 4-20 mA source of the CLX-XT.

8.3 Desiccant Cartridge Option (Catalog #09944)

An optional desiccant cartridge kit can be purchased for use in applications where condensation on the glass cuvette may compromise accuracy. The desiccant changes color from blue to pink when expended. Instructions for replacement are included with the kit.

8.4 Standby Reagent Purge (Software Option Cat #25316)

During times when the CLX-XT is not being operated such as in voyage between ballasting and deballasting no reagent moves past the check valves. In some instances this can cause these parts to clog. To prevent this occurrence a single pump action is enabled at a timed interval.



It is important that the unit remain in Standby Mode and power is always applied.

This software feature is available on select software packages where either Modbus or the Hardware Remote Standby feature is used.

Every time the instrument is placed in standby mode a timer starts. Once the set time has elapsed a single action of the reagent pump occurs to keep the check valves clear. This single will inject about 25 μ L of each reagent into the chamber. This is performed with a special pulse width modulation to prevent the reagent from splattering and staining the measurement glass.

Note that for the timer to be active, power must be constantly applied to the instrument. If the power is removed or a power disturbance occurs the timer is reset.

The default factory time setting is once every 24 hours. This time period can be adjusted if desired at Modbus Address 40025 which is an integer. The allowable setting range is 1 hour to 100 hours.

8.5 Reset Reading to Zero (Software Option Cat # 25316)

If there is a need to reset the reading to Zero this can be accomplished in most software packages through Modbus. The address is 00006. The default setting is false (0) setting this to true (1) will set the reading to Zero and the completion on the next cycle. This setting also affects the 4-20mA output and alarms.

8.6 AutoPurge (Hardware option Cat# 25279)

If power is removed from the CLX-XT without stopping the unit first, there is a good chance that sample water and possibly reagents are left in the optics. Over a period of time this can stain the cuvette. This factory installed option stores a charge in a super-capacitor. During an unexpected removal of power the stored charge is used to open Purge solenoid.

9.0 Troubleshooting

9.1 CLX-XT Fault Detection

The CLX-XT performs continuous diagnostic monitoring. In the CLX-XT, there are 4 severity levels of fault detection. Level 4, 3 & 2 will allow normal operation, but warn of the problem. Level 1 is an instrument failure and the instrument will not operate. Any faults are displayed in a queue form in the bottom row of the LCD.

A **level 4 fault** is simply a screen indication that one of the alarm levels has been activated. This fault level will not affect the 4-20 mA and will only affect the alarm activated. The sample back light blinks at a rate of once every 4 seconds.

A **level 3 fault** indicates a failure or a problem that usually can be corrected by the operator. Refer to the chart below. If any of these errors occur, the instrument will still display readings and probably will operate correctly. These faults will self-clear when the problem is corrected. If any of these faults occur, they may affect the 4-20mA and any alarm dependent on fault detection setting (Error). See sections 7.2 & 7.41 for error settings. The sample back light blinks at a rate of once every 2.5 seconds to indicate a level 3 fault.

Level 3 (Self-Clearing) fault conditions

Message	Description of Fault	Corrective Action
MA	4-20 mA enabled & loop open	Check 4-20 mA wiring or turn off 4-20mA if not used
CAL	Calibration invalid –not accepted	Recalibrate if needed
WATR	No water flowing	Check water flow
FAST	Intake water flow too fast	Set flow rate (see section 9.2)
SLOW	Sample cuvette filling too slowly	Set flow rate (see section 9.2)
PURG	Sample cuvette has slow purge	Check drain lines
NPRG	Sample cuvette not purging	Check drain lines
ISOL	Problem with intake solenoid	Check wiring, check for clogged solenoid
PSOL	Problem with purge solenoid	Check wiring, check for clogged solenoid
GLAS	Dirty cuvette	Replace or clean cuvette
WCAL	Water Level Calibration Invalid	Clear fault (see section 9.3)

A **level 2 fault** indicates a severe problem that will usually require technical assistance from HF scientific customer service (see section 9.6). The queued display will show **POST**. If this fault occurs it will affect the 4-20mA and any alarm set for fault detection (Error). The sample back light blinks at rate of once every 1 second.

A **level 1 fault** is a system fault. This is NOT a problem that the operator can correct, and the unit must be returned to the factory for service (see section 9.5). These failures consist of failures in the CPU, A/D, EEPROM or other devices internal to the instrument. The queued display will show **FAIL**, the upper display will show a four or five digit fault code. If this fault occurs, it will affect the 4-20mA and any alarm set for fault detection (Error). The instrument will not operate with this fault. The sample back light blinks at rate of once every 0.4 seconds.

If any fault condition occurs, the message indicating the fault will be shown on the lower row of the display.

9.2 Setting Flow Rate

The flow rate on the CLX-XT was factory adjusted and usually should not need adjustment. Installation variances may affect the flow. The optimal flow rate through the CLX-XT may be adjusted if needed. The flow is adjusted by removing regulator vinyl cap and turning the adjustment screw on the pressure regulator. To assist in this adjustment follow the procedure shown below:

1. Press the **SERVICE** button.
2. Wait for the display to read HOLD, then press **Mode/ Exit**.
3. Display will show FLOW with the number 0. Press either the ▲ or ▼ button.
4. CLX-XT will drain, and then pulse in water while a count is displayed on the screen.
5. The display will show one of three messages HI, LO or Good.

The flow test determines if the flow rate is suitable for proper operation. Loosen the locking nut then adjust the pressure regulator using a coin or a large flat blade screwdriver. Press either the ▲ or ▼ button while in the FLOW routine to display a new flow rate. Please note that only ¼ turn incremental adjustments should be made to the regulator on each attempt.

If the message is LO, turn the regulator control clockwise. If the message is HI, turn the regulator counterclockwise. If the message is Good, no adjustment is required. Tighten the locking nut after adjustment and replace the regulator vinyl cap. To return to normal operation, press the ↵ button.

9.3 Clearing Faults

Every time **SERVICE** mode is exited, all faults are cleared. If the original fault or a new fault occurs, it will be posted.

In the case of WCAL, it is possible the power was enabled before a water sample was available. Ensure a water sample is available and then press **PRIME** to force another Water Calibration (WCAL). The Water Calibration occurs automatically at the completion of the 75 **PRIME** strokes.

9.4 Reagent Clogs

If reagents fail to flow or Prime it may be due to a clog in either the tubing or at a check valve. To alleviate this you may have to flush the system with Chlorine Free water, preferably Deionized water. See section [10.3 Check Valve Flushing Kit](#).

9.5 Diagnostic Chart

Symptom	Cause	Cure
Lower display shows MA	4-20 mA loop open	Check wiring. See sections 4.3.4 and 7.2
Lower display shows FAIL	Major system fault	Refer to section 9.1
Readings are erratic	(1) Bubbles in solution (2) Debris in flow	(1) Install bubble elimination chamber. (2) Clean T-strainer
Readings are lower than expected	(1) Condensate or leaky measurement cuvette (2) Measurement cuvette dirty (3) Reagents bad or expired (4) Buffer reagent not being dispensed	(1) Install desiccant cartridge kit (2) Replace or clean cuvette (3) Replace reagents (4) Check buffer lines and check valves.
Upper display flashes	Sample Over-Range	Check sample. Sample may be too high to read.
Upper display shows nOnE while attempting to calibrate	No current reading displayed	Wait for CLX-XT to post a reading

9.6 Technical and Customer Assistance

If for any reason assistance is needed regarding this instrument please do not hesitate to contact either the HF scientific Technical Service Department or the HF scientific Customer Service Department:

HF scientific
16260 Airport Park Drive, Suite 140
Fort Myers, Florida 33913
Phone: (239) 337-2116
Toll Free (888) 203-7248
Fax: (239) 454-0694
Email: hf.info@wattswater.com
www.hfscientific.com

10.0 Routine Maintenance

10.1 Maintenance Schedule

The recommended schedule is shown below. It is important to replace the reagents to get reliable accurate readings from the CLX-XT. The Buffer supplied can last for up to one year*. Each mixed indicator reagent will last for up to 90 days* when kept in cooling chamber. The one year kit includes one buffer bottle and four sets of indicator reagents. A convenient mounting clip for the indicator reagent box is located in the lower left corner of the cabinet. The Buffer reagent mounts above the indicator reagents in another clip and is further held with a Velcro strap. See section 10.2 for more information on the reagents.

The CLX-XT is shipped with one CLX-XT Tubing/Cuvette kit, HF part # 09950XT. The kit consists of the following:

<u>Qty</u>	<u>Part</u>
1	Spare Buffer Cap Assembly
1	Spare Indicator Cap Assembly
8	Pump Tubes
1	Spare Cuvette

Two replacement sets of reagent cap/tubing assemblies are supplied with the CLX-XT; one for the buffer and one for the indicator.

Additional kits can be ordered from your local HF scientific distributor or representative. It is recommended to keep one kit on hand at all times.

Generally, both pump tubes should be replaced annually. Spare cap assemblies for both the buffer and the indicator are supplied and can be replaced when needed.

Every 30 days

1. Check for leaks and proper operation of the instrument in general.
2. Check the T-strainer for debris. Clean if needed.
3. Check the cooling chamber operation using a non-contact IR thermometer. This should be 25°C or lower.

Every 90 days

1. The indicator reagent required for operating this instrument must be changed at least every 90 days. The buffer reagent can be used up to one year.
2. The internal strainer should be checked and cleaned if necessary.
3. The glass cuvette should be inspected. Check for excessive debris on the inside surface of the glass. It is suggested to keep a spare cuvette to replace when required. The old cuvette may be cleaned, if possible, for future replacement.

Flushing the System

Press the SERVICE button to stop the water flow. Remove old reagents and discard. Place the suction tubes in a small container of clean water. Press SERVICE to return to operation mode, press PRIME and then ↵ to flush the system with water. Remove the suction tubes from the water Press PRIME and then ↵ to remove most of the water.



After a PRIME the CLX-XT will perform a water calibration (WCAL). It will take a few minutes to complete this procedure.

**The 1 year buffer and 90 day indicator reagent life is primarily used on ballast water applications. The assumption is based on the factory default of a 60 second cycle and up to 24 hours total operation per month.*

Pump Tubing Replacement

The black pump tubes may need replacement more often due to the fact that they are subject to wear. The inline check valves should not need to be replaced and should be saved. Please note that the check valves are directional as shown below.

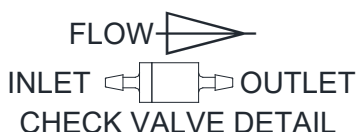

Steps:

- 1 Flush the system as described above to reduce personal contact with the reagents.
- 2 Press SERVICE to stop the flow of sample water and drain the cuvette.
- 3 Remove and retain the thumb screw on top of the pump; pull the pump hammer and spring up and out of the way. There is no need to completely remove the hammer and spring.
- 4 Working on one reagent side at a time. Replace the black tubing between optics inlet and the check valve OUTLET. Discard the old tubing.
- 5 Ensure the check valve is placed into its seat.
- 6 Repeat steps 4 & 5 for the other reagent.
- 7 Replace the hammer and spring back into place and secure with the thumb screw.
- 8 Check the drawing on the following page to ensure correct installation.
- 9 Return to operation as described.

Cap Assembly Replacement

When the Cap Assemblies needs to be changed follow the procedure shown below. It is recommended that both assemblies are changed at the same time.

Steps:

- 1 Flush the system as described above to reduce personal contact with the reagents.
- 2 Press SERVICE to stop the flow of sample water and drain the cuvette.
- 3 Remove the buffer cap assembly from the cabinet vent and the connection at the check valve.
- 4 Replace the buffer cap (blue or black cap) assembly. Note that the vent tube is not centered and does not connect to the suction tube.
- 5 Repeat steps 3 & 4 for the indicator side (white cap).
- 6 Replace reagents, prime and return to service.

Cuvette Replacement

Check the condition of cuvette and change if it appears badly soiled or discolored. Follow the steps below.

Steps:

1. Replace the two Cap Assemblies.
2. Turn the knurled top on the optics system counterclockwise (as viewed for the top) until the cuvette just “pops” out, but do not remove the top.
3. When the cuvette “pops” out, move the retaining o-ring & remove the cuvette. You may need a stiff wire such as a bent paper clip to grasp the cuvette. Retain this cuvette for future use if it can be cleaned.
4. Install the new cuvette by pushing it firmly in place and turning the knurled top clockwise until the cuvette is held securely.
5. Check the drawing on the following page to ensure correct installation.
6. Return to operation as described.

T-Strainer Cleaning

The T-strainer is integral to the instrument and must be checked occasionally. When necessary it must be removed and cleaned. The strainer screen may require replacement after a period of time.

Steps:

1. Press SERVICE to stop the flow of sample water and drain the cuvette.
2. Ensure the source water is turned off.
3. The T-strainer is clamped to the intake regulator. The removal requires the use of a flat blade screwdriver as shown in the photo. Once the two clamps are opened the T-strainer can be removed.
4. Disconnect the top of the T-strainer and regulator from the tubing and clear of the case.
5. Clean the T-strainer screen and replace.
6. Be sure to tighten the bowl of the strainer.
7. Be certain the clamps are tightened fully and the tubing connections are complete. Pliers may be required to close the clamps.
8. Turn source water back on.
9. Return to normal operation.
10. Check for any leaks.

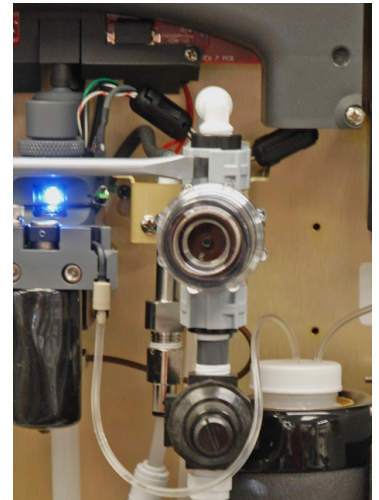

Return to Normal Operation

Press the SERVICE button to return sample flow to the system. Check for leaks. If a leak occurs press SERVICE again, repair leak and try again. Once the system is operating correctly, return or replace reagents and press PRIME and then ↵ one time to restart reagent flow. The system will automatically return to normal operation.



Tubes may darken due to contact with the reagent. This condition does not affect the performance of these parts.

10.2 Replacing or Installing the Reagents

Reagent kits are available from HF scientific for Total Chlorine Refer to **section 11.0 Replacement Parts and Accessories** for the appropriate Catalog number. There are two reagents required, for the instrument to operate; the **buffer** and the **indicator**.

The reagents are provided “wet” and the buffer is ready to use and will last up to one year.

The smaller indicator reagent does require the addition of the DPD power to activate it. Once activated it starts to oxidize. This process is slowed by keeping it in the cooling chamber.



When commissioning the CLX-XT it is recommended to follow the procedure in section 10.3. This procedure only needs to be done once when the instrument first commissioned.

Indicator Reagent Preparation

Remove the cap of the small liquid indicator reagent and add the contents of the DPD powder bottle (small brown bottle). Cap and shake to fully dissolve the powder.



Once mixed the indicator has an expected life of up to 90 days if kept in the powered cooling chamber. Write the mixing date on the reagent bottle labels in the area provided. Dispose of expired reagents correctly.

To replace the reagents, press the **SERVICE** button; this will empty the cuvette and stop any flow of water. Remove the cap on both bottles replace with the cap supplied with the CLX-XT. The buffer is installed on the left and the indicator is installed in the cooling chamber. The suction tube for both reagents will reach the bottom of the bottles.

To complete the replacement procedure, press the **PRIME** button and then the **←** button. This will draw enough of each reagent to completely prime the tubes and replace any old solution. The system will automatically return to normal operation after it has primed.

CAUTION

Use caution when changing the reagents as they are corrosive. These reagents may stain clothing. After changing the reagents, operators should wash their hands.

10.3 Check Valve Flushing Kit

Sometimes upon initial commissioning, the check valves stick and require manual priming. This should not be needed after commissioning. Be careful when using this kit to use only chlorine free water. Complete instructions are included in the kit.

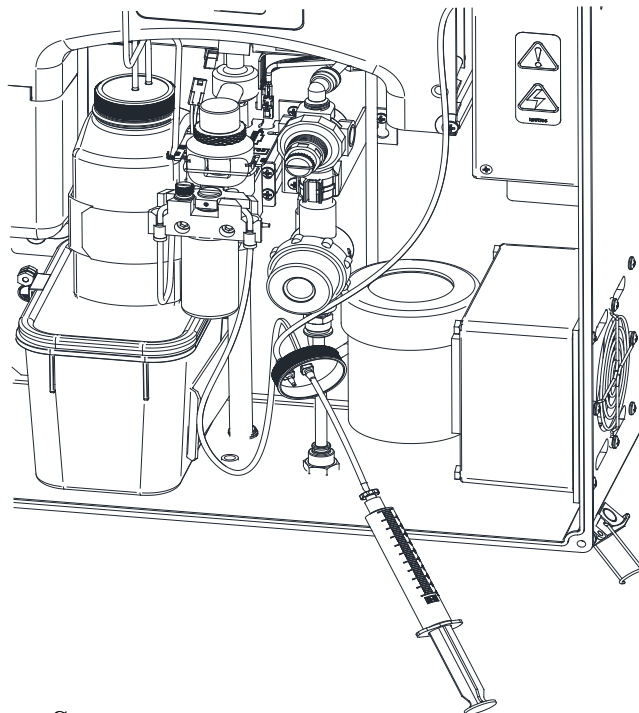

10.4 Instrument Storage

If the CLX-XT is relocated or will be inactive for long periods of time, remove the reagents. Flush the reagent system as describe in [10.1 Maintenance Schedule](#). Or use the flush kit to rinse out unused reagents. Place the instrument in Service mode to drain the system then remove power by disconnecting the mains power plug. It is usually a good idea to disconnect or shut off the source water.

10.5 Cleaning the CLX-XT

Flush the system as mentioned in section [10.1 Maintenance Schedule](#). When the flushing is finished, press the SERVICE button wait until the display reads HOLD.





As a matter of safety, always disconnect any power source to the CLX-XT prior to attempting any cleaning. It is recommended that the source water is also shut off.

Isopropyl alcohol (rubbing alcohol) on a soft cotton cloth works very well in removing reagent stains from plastic parts, the keypad and the display. Use care when cleaning around electrical components. Do not use any harsh cleaning agents as these may cause damage to the instrument components. Do not allow the alcohol to touch the Strainer as it may be damaged.

Ensure that the system is dry prior to applying power.

11.0 Accessories and Replacement Parts List

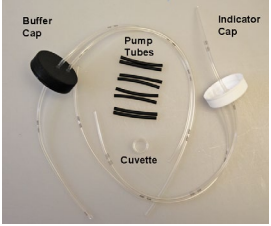
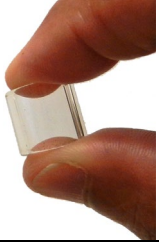
The items shown below are recommended accessories and replacement parts.

Accessory	Catalog Number	Photo
Check Valve Flushing kit	25096	
Reagent Kit – Total Chlorine 12 month supply	09991	
Operating Manual CLX-XT	28652	N/A
Tubing/Cuvette Kit	09950XT	
Replacement Cuvette	25018S	
Check Valve Kit	25017S	

Ferrite for 4-20mA or RS-485	24560	
Strainer & Regulator Assembly	25357	
Replacement T-strainer Screen	28625	
Intake Assembly (solenoid, regulator & T-strainer)	28411	

To order any accessory or replacement part, please contact the HF scientific Customer Service Department. If for any reason technical assistance is needed regarding this instrument, please do not hesitate to contact the HF scientific Technical Services Department.

HF scientific
16260 Airport Park Drive, Suite 140
Fort Myers, Florida 33913
Phone: (239) 337-2116
Toll Free: (888) 203-7248
Fax: (239) 454-0694
Email: hf.info@wattswater.com
www.hfscientific.com

12.0 Limited Warranty

HF scientific, LLC (the "Company") warrants each ballast water market product to be free from defects in material and workmanship under normal usage for a period of two (2) years from first use or three (3) years from date of the Company's invoice from the original sale of the product, whichever occurs first. In the event of such defects within the warranty period, the Company will, at its option, replace or recondition the product without charge. Parts, which by their nature are normally required to be replaced periodically, consistent with normal maintenance, specifically reagent, desiccant, sensors, electrodes and fuses are excluded. Also excluded are accessories and supply type items.

Proof of purchase from the company (Company invoice or paid order confirmation) and/or first use (commissioning) must be provided when making a product warranty claim.

THE WARRANTY SET FORTH HEREIN IS GIVEN EXPRESSLY AND IS THE ONLY WARRANTY GIVEN BY THE COMPANY WITH RESPECT TO THE PRODUCT. THE COMPANY MAKES NO OTHER WARRANTIES, EXPRESS OR IMPLIED. THE COMPANY HEREBY SPECIFICALLY DISCLAIMS ALL OTHER WARRANTIES, EXPRESSED OR IMPLIED, INCLUDING BUT NOT LIMITED TO, THE IMPLIED WARRANTIES OR MERCHANTABILITY AND FITNESS FOR A PARTICULAR PURPOSE.

The remedy described in the first paragraph of this warranty shall constitute the sole and exclusive remedy for breach of warranty, and the Company shall not be responsible for any incidental, special or consequential damages, including without limitation, lost profits or the cost of repairing or replacing other property which is damaged if this product does not work properly, other costs resulting from labor charges, delays, vandalism, negligence, fouling caused by foreign material, damage from adverse water conditions, chemical, or any other circumstances over which the Company has no control. In addition, the Company shall not be responsible for any costs incidental to the Company's warranty response efforts, including, without limitation, costs associated with the removal and replacement of systems, structures or other parts of facilities, de-installation, decontamination and re-installation of products, or transportation of products to and from the Company. This warranty shall be invalidated by any abuse, misuse, misapplication, improper installation or improper maintenance or alteration of the product.

Some States do not allow limitations on how long an implied warranty lasts, and some States do not allow the exclusion or limitation of incidental or consequential damages. Therefore the above limitations may not apply to you. This Limited Warranty gives you specific legal rights, and you may have other rights that vary from State to State. You should consult applicable state laws to determine your rights. **SO FAR AS IS CONSISTENT WITH APPLICABLE STATE LAW, ANY IMPLIED WARRANTIES THAT MAY NOT BE DISCLAIMED, INCLUDING THE IMPLIED WARRANTIES OF MERCHANTABILITY AND FITNESS FOR A PARTICULAR PURPOSE, ARE LIMITED IN DURATION TO ONE YEAR FROM THE DATE OF ORIGINAL SHIPMENT.**

Notes

Notes